

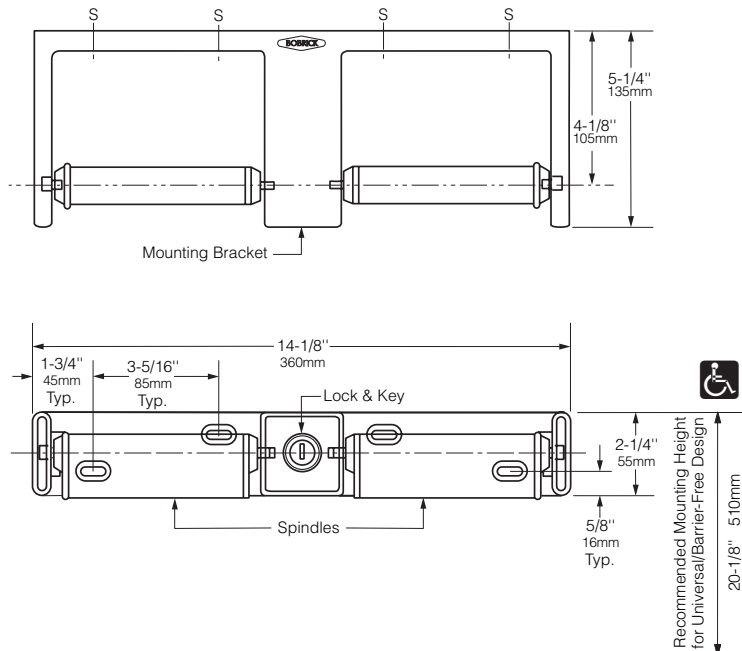

Patented



MATERIALS:

Bracket — Heavy-duty cast aluminum with satin finish. Equipped with a tumbler lock that is keyed like other Bobrick washroom accessories.

Spindles (2) — Molded high-impact ABS.

OPERATION:

Accommodates two standard-core toilet tissue rolls up to 6" (152mm) diameter (2000 sheets). Tumbler lock secures spindles in place; spindles can only be removed after unlocking with key furnished. Vandal-resistant.

INSTALLATION:

For partitions with particle-board or other solid core, provide sheet-metal screws or through-bolts, nuts, and washers.

For hollow-core metal partitions, provide solid backing into which sheet-metal screws can be secured. If two units are installed back-to-back, then provide threaded sleeves and machine screws for the full thickness of partition.

For plaster or dry wall construction, provide concealed backing to comply with local building codes, then secure unit with sheet-metal screws.

For masonry walls, provide sheet-metal screws and fiber plugs or expansion shields, or provide 1/8" (3mm) toggle bolts or expansion bolts.

SPECIFICATION:

Double-roll toilet tissue dispenser shall have a heavy-duty cast-aluminum bracket with satin finish. Bracket shall be equipped with a tumbler lock to secure spindles in place. Vandal-resistant spindles shall be molded high-impact ABS. Unit shall accommodate two standard-core toilet tissue rolls up to 6" (152mm) diameter (2000 sheets). Manufacturer's service and parts manual shall be provided to the building owner/manager upon completion of project.

Double-Roll Toilet Tissue Dispenser shall be Model B-27460 of Bobrick Washroom Equipment, Inc., Clifton Park, New York; Jackson Tennessee; Los Angeles, California; Bobrick Washroom Equipment Company, Scarborough, Ontario; Bobrick Washroom Equipment Pty. Ltd., Australia; and Bobrick Washroom Equipment Limited, United Kingdom.