

Standard Heavy Duty Double Lever Arm Application. For Field Reversible Units.

Stop (Push) Side of Door Installation for Door Openings 85 to 110°

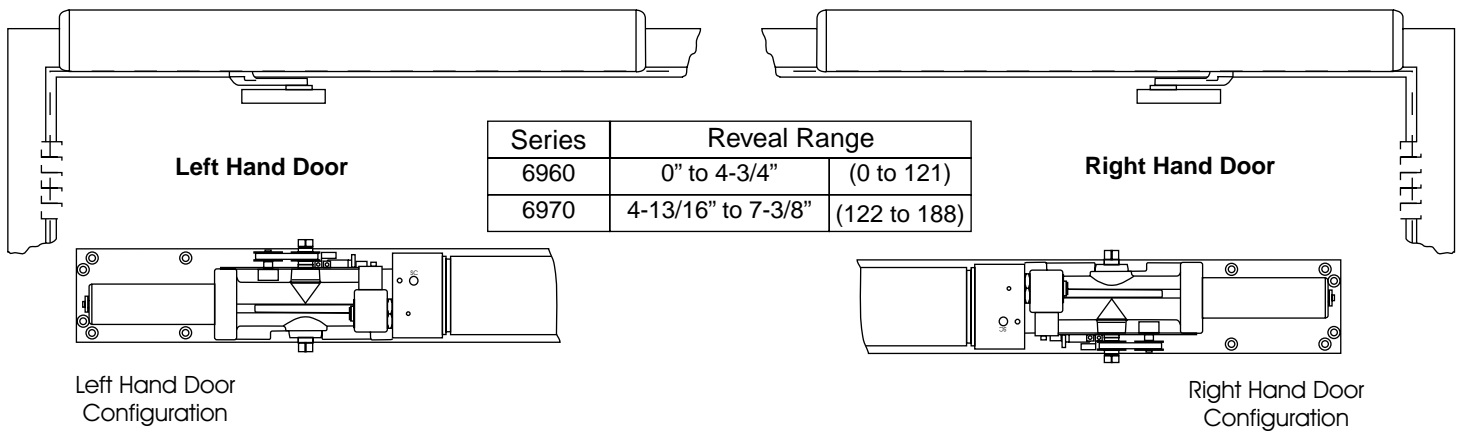

IMPORTANT * See Page 2 for Selector Mode Switch Location Before installing unit to Frame

Activation Modes (Modes are configured during installation.)

- **Selectively Activated Mode** - unit depends upon external switches or scanners for activation of functions.
- **Automatically Activated Mode** - unit will operate with a slight movement of the door toward the open position utilizing on-board ELS switching that automatically activates the functions. External switches or scanners may also be used for activation.

Functions (Functions are configured during installation.)

- **Power Operator function (POR)** – The unit performs as a low energy power door operator. Field settings allow for following two functions:
 1. Selectively Activated Mode (See Above).
 2. Automatically Activated Mode (See Above).
- **Power Assist function (PAS)** – The unit operates as a standard door closer unless activated via one of the Modes listed above. Upon activation the door opening resistance is reduced, for a selected period of time, well below A.D.A. guidelines. When the time period expires, the door closes under normal door closer spring power.

NOTE: The ELS Board Dip Switches are factory set in the Selectively Activated Mode as a Power Operator Function.

Americans With Disabilities Act (A.D.A.)

These door operators can be installed and adjusted to conform with A.D.A. regulations.

ANSI Standards



ANSI A117.1 – These door operators permit door assemblies to conform to the requirements of this specification "for buildings and facilities – **providing accessibility and usability for physically handicapped people**".

- **ANSI A156.19** – These products are designed to conform to this specification "**for power assist and low energy power operated doors**".
 - "PAS" Function is designed to meet or exceed all of the requirements for the "Power Assist Door".
 - "POR" Function is designed to meet or exceed all of the requirements for the "Low Energy Power Operated Door".

U.L. Listing



Underwriters Laboratories, Inc. listed for use on fire and smoke barrier door assemblies when the 120VAC (60Hz) power input is supplied through the normally closed alarm contacts of a compatible U.L. Listed alarm system or alarm panel.

WARNING

120 VOLT POTENTIAL PRESENT. MAKE SURE
POWER IS TURNED OFF DURING
INSTALLATION PROCEDURE.

CAUTION

An incorrectly installed or improperly
adjusted door operator can cause property
damage or personal injury. These
instructions should be followed to avoid the
possibility of misapplication or
misadjustment.

Basic Requirements.....	2	General Product Information.....	6
Parts Identification.....	2	Function and Operation Sequence	6
Installation Template.....	3	ELS "Timing" Calibration	7
Installation Sequence.....	4	ELS Reset Instructions	8
Regulation & Adjustment.....	5	Troubleshooting	8

Requirements

- U.L. labeled fire or smoke barrier door assemblies require that the 120VAC (60Hz) power input to the PowerMatic™ door operator be supplied through normally closed alarm contacts of the alarm system/alarm panel.
- Power input to PowerMatic door operator must be 120 VAC (60Hz) to terminals HOT and COM at terminal strip T1. Terminal GND is earth ground.
- All wiring must conform to standard wiring practice in accordance with national and local wiring codes.
- Note: Unless otherwise noted, all dimensions are given in inches (millimeters).
- Minimum frame face 2" (51mm).
- Minimum ceiling clearance 4-1/2" (114.3mm).
- Minimum suggested and required material thickness for hollow metal frames (skin plus reinforcement) is charted on page 3.
- For wiring refer to Wiring Instructions.
- Hand of unit is reversible.
- Door must be hung on butt hinges [5" (127mm) max. width] or 3/4" (19mm) offset pivots. A separate door and frame preparation template will be supplied for other conditions.
- Door thickness must be 1-3/4" (44mm) minimum, 2-1/4" (57mm) maximum.
- Door must swing freely through the entire opening and closing cycle before beginning the installation.
- Use of a supplemental door stop is always recommended.

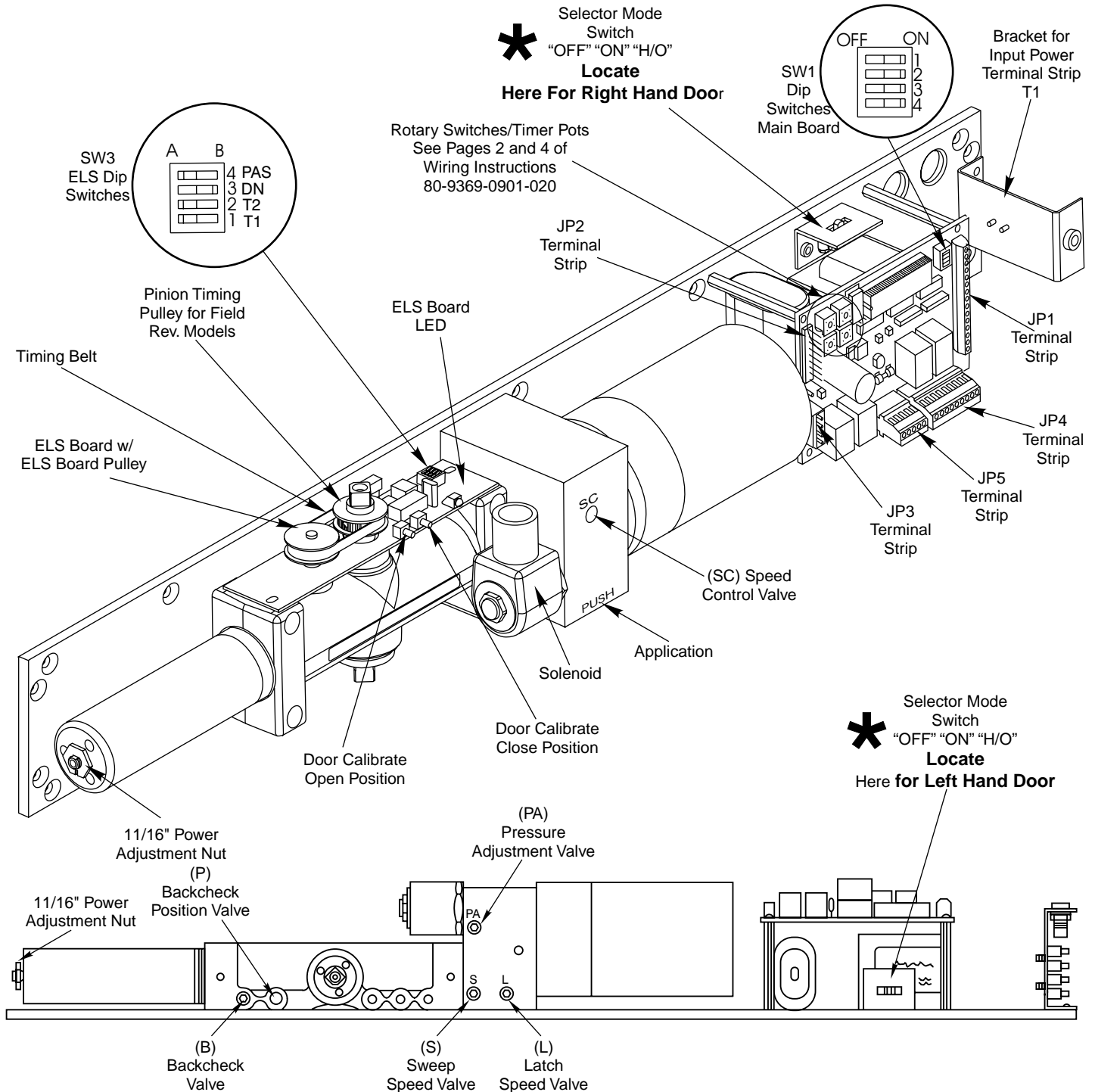

DETERMINE HAND OF DOOR

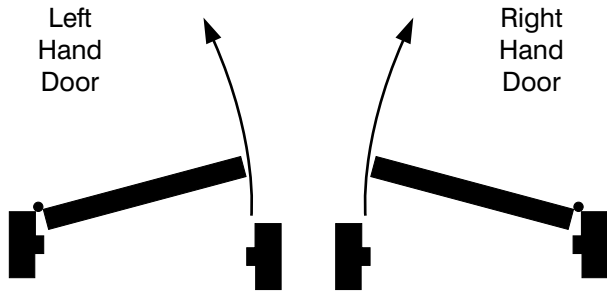

Hollow Metal Door Frame Reinforcing		
Frame Material	Reinforcing	
	Recommended	Min. Required
12 Ga. .1046 (2.66)	12 Ga. .1046 (2.66)	18 Ga. .0478 (1.21)
14 Ga. .0747 (1.90)	10 Ga. .1343 (3.41)	12 Ga. .1046 (2.66)
16 Ga. .0598 (1.52)	10 Ga. .1343 (3.41)	12 Ga. .1046 (2.66)
18 Ga. .0478 (1.21)	8 Ga. .1644 (4.18)	10 Ga. .1343 (3.41)

General

- Before beginning the installation, verify that the door frame is properly reinforced and is well anchored in the wall. Unreinforced hollow metal frames and aluminum frames should be prepared and fitted with 1/4-20 blind rivet nuts, furnished by the installer.
- Concealed electrical conduit and concealed switch or sensor wires should be pulled to the frame before proceeding.

Fasteners for Frame

- 1/4-20 Machine screws for hollow metal and aluminum.
- No. 14x2-3/4" (70mm) long wood screws.

Fasteners for Door

- 1/4-20 Machine screws.
- 3/8" diameter x 1-3/4" (45mm) long sex nut..

WARNING: Make sure that (120V, 60Hz) input power is turned off before proceeding with installation.

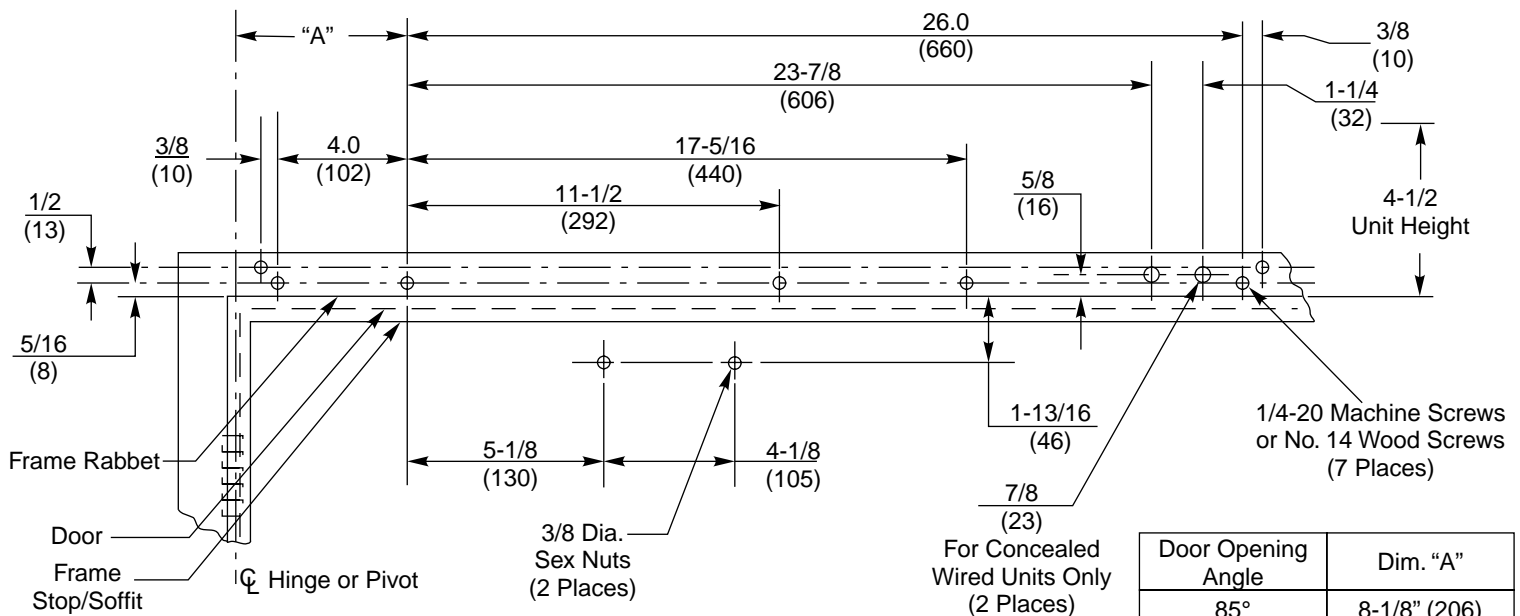

Series	Reveal Range
6960	2-1/4" (57) to 4-3/4" (121)*
6970	4-13/16 (122) to 7-3/8" (188)

* Reveals less than 2-1/4" (57) may be achieved by field cutting the adjusting rod.

Door Opening Angle	Dim. "A"
85°	8-1/8" (206)
90°	7-1/2" (191)
95°	6-7/8" (175)
100°	6-3/8" (162)
105°	6-0" (152)
110°	5-5/8" (143)

Notes:

- Do not scale drawing.
- Left hand door shown.
- All dimensions are given in inches (mm).
- Thickness recommended for reinforcements in hollow metal doors and frames is charted at the top of this page.

• This template information based upon use of 5" (127mm) maximum width butt hinges or 3/4" (19mm) offset pivots. A separate template will be supplied for other conditions.

• Conduit hole farthest from hinge is suggested for 120 VAC power input.

Installation Sequence

- Determine hand of door from illustration on Page 3.
- Locate Selector Mode Switch in proper location. See Page 2. Remove two (2) #8 screws holding Selector Mode Switch to backplate, position switch in the proper location based on handing of door so switch is viewable and accessible when unit is mounted on frame.

Note: Unit is shipped from factory with switch in “Left Hand” Location.

- Using template, locate and prepare holes in the frame and door:

Frame

- **Concealed Wired Units Only:** Two (2) 7/8" (22mm) diameter holes for conduit, for power input and for switch/sensor wires. NOTE: On new construction these holes will generally be drilled by the frame supplier at their shop or at the time the frame is installed in the wall.
- Prepare **seven (7)** holes for 1/4-20 machine screws or No. 14 x 2-3/4" (70mm) wood screws. Blind rivet nuts (by others) are suggested for unreinforced hollow metal frames or for aluminum frames.

Door

- Prepare **two (2)** holes for 3/8" diameter sex nuts. Standard units are supplied with sex nuts and screws for 1-3/4" (44mm) thick door. Sex nuts and screws for other door thicknesses are available to order.
- Remove cover from door control assembly and set cover and cover screws aside.
- Verify the Selector Mode Switch is in the proper location based on Hand of Door. ✱ See Page 2. Remove **two (2)** #8-32 flat head screws that secure Switch Assembly to backplate and locate switch in one of the locations shown on page 2. Re-attach using #8-32 screws.
- Fasten backplate/control assembly to frame face
 - **Concealed Wired Units Only:** Connect conduit to backplate **before** fastening backplate to frame.
 - **Surface Wired Units Only:** Fasten backplate to frame. Connect conduit bracket, from screw pack, to the door control's backplate with two (2) screws provided. Then connect wiring conduit to conduit bracket on backplate.
- Remove forearm screws from the arm adjusting rod and disassemble the adjusting rod and arm snubber shoe assembly from the arm assembly.

NOTE: Series 6960 Only.

If the frame reveal is less than 2-1/4" (58mm), use a saw and cut 1-7/8" (48mm) off the end of the adjusting rod.

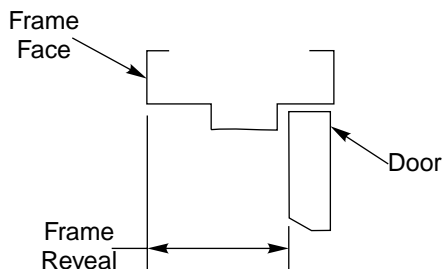

- Fasten adjusting rod and arm snubber shoe assembly to the door with the long end of the arm snubber shoe nearest to the hinge and the adjusting rod on top of the arm snubber shoe.
- Slide the main arm onto the pinion shaft of the door control unit at approx. 90° angle to the door control unit and the frame. Align the centerline of the arm with the flat corner of the pinion shaft square (see illustration above right).

- Install and tighten 1/4-20 Flange Head Screw with 7/16" wrench or socket.

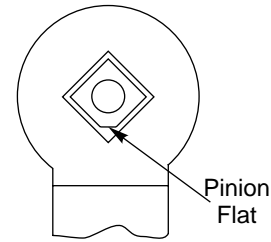

- Open Door. Align and insert adjusting rod into the arm slide. Close Door.
- Rotate the main arm away from the hinge until the adjusting rod and arm slide are perpendicular (at a 90° angle to the door). Secure at 90° angle with the forearm screw.

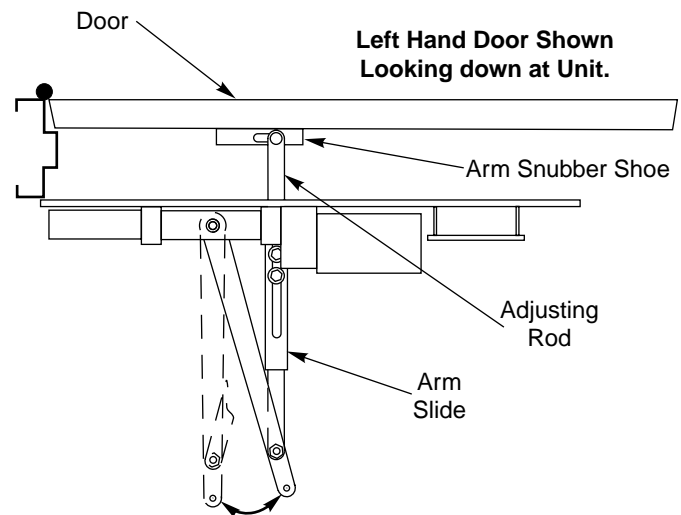

- Adjust valves “S” and “L” using the 1/8" hex wrench provided. See Hydraulic Adjustment Page 5
- Note: A.D.A. Requires that from an open position of 70° the door will take at least 3 seconds to move to a point 3" (75mm) from the latched position, measured at the leading edge of the door.
- Make wire connections using Wiring Instructions No. 80-9369-0901-020

IMPORTANT:

- **Power Operator Units Only:** The opening speed of the door from closed position to 80 degrees must be 3 seconds or longer and 4 seconds or longer to the fully open position.
- **Power Operator Units Only:** The force required to prevent a door from opening or closing must not exceed a 15lbf. (67N) applied 1" (25mm) from the latch edge of the door at any point in the opening or closing cycle.

TEACHING CLOSED AND OPEN DOOR POSITIONS:

Before operating, the PowerMatic 6900 must be “taught” the fully closed and fully open door positions.

- ELS board comes from factory with potentiometer “timed” and ready for unit to be taught open and closed door positions.

⚠ WARNING: Verify that dip switch #3 on the ELS board is in the “A” position to disable the Push and Go Feature. Verify the Selector Mode Switch is in the “OFF” position (Page 2)

- Turn Power Input to Unit “ON”.
- With the door fully closed, press and release the BLACK pushbutton on the ELS board. The ELS system will store this position as closed and begin the 10 second “Teaching Mode”.
- Within the 10 second time frame, manually open the door to the desired fully open position. While holding the door open in this position, press and release the WHITE pushbutton on the ELS board. The ELS system will store this position as open.
- Let the door return to the closed position. This will end the “Teaching Mode” regardless if the 10 second time frame has elapsed.
- Set the Selector Mode Switch to the “ON” position for normal operation or “H/O” for indefinite hold open.

✳ NOTE: If unit does not respond to teaching or if the ELS LED began flashing when power input was first turned on and continues to flash, see ELS Reset Instructions on page 8.

Activation Mode – (Push and Go)

Mode	Push And Go	ELS Dip #3 DN
Selectively Activated	DISABLED	A
Automatically Activated	ENABLED	B

Functions – Power Operator / Power Assist:

Function	ELS Dip #4 PAS	Main Board Dip #1 P/A
Power Operator	B	OFF
Power Assist	A	ON

- Rotate the “SC” Valve Counter-Clockwise to adjust opening speed (POR) or opening force (PAS).
- Rotate the “PA” Valve Clockwise if needed to adjust pressure.

Power Assisted Opening: Adjust the “SC” valve so the the door does not open when activated, but opening force is reduced below A.D.A requirements. The “PA” valve is factory set and should not need adjustment. Adjust if needed to obtain proper opening forces. (See illustrations on page 2 for Dip Switch and Valve location.)

Obstruction Operation:

Obstruction During Opening:

The door will stop and close under spring force.

Obstruction During Closing:

The door will stop and the unit will reopen the door. If the Obstruction During Closing is detected a second time, the door will not attempt to reopen and will attempt to close under spring force.

Obstruction Sensitivity

The time delay of the obstruction feature can be adjusted in the field as required. The unit has been factory-configured to respond immediately to an obstruction. In certain applications where excessive wind or excessive stack pressure is present, a delay of 1, 3, or 5 seconds can be selected by toggling dip switches T1 and T2 on the ELS board.

OBSTRUCTION DIP SWITCH SETTINGS:

Time	ELS Dip Switch T1	ELS Dip Switch T2
Immediate	B	B
1 Sec.	A	B
3 Sec.	B	A
5 Sec.	A	A

Adjustments for the PowerMatic Product

The following adjustments mechanical, hydraulic and electrical are listed in a suggested sequence.

NOTE: Make sure that power to unit is OFF.

MECHANICAL ADJUSTMENT

- Set Closing Power. Use 11/16" wrench or socket. Turn Power Adjustment Nut clockwise to increase door closing power. Door control is shipped set at midpoint of power setting. Maximum closing power can be achieved with 5 (360°) turns of the power adjustment nut for a regular PowerMatic, 7 turns if unit is a Barrier Free (BF) unit.

HYDRAULIC ADJUSTMENT – Use 1/8" hex wrench

- Closing Cycle – Make adjustments, as necessary, to the Sweep Speed "S" valve and Latch Speed "L" valve. See illustration on Page 2. Turn valves clockwise to reduce speed, counter clockwise to increase speed.

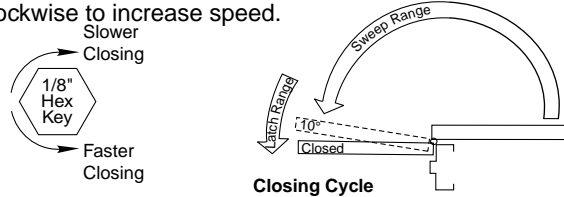

- Opening Cycle – Adjust Backcheck, "B" valve, as necessary, for hydraulic resistance to door opening in the backcheck range. See illustration on Page 2.

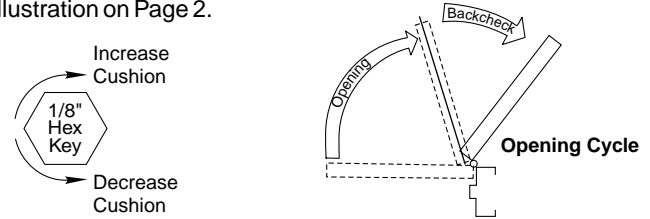

NOTE: Too much Backcheck, "B" valve, can affect the operation of the units pump, preventing units from fully opening the door. This valve may require fine tuning after all other adjustments have been made.

- Backcheck Position "P" valve is closed. Open by turning counter clockwise, only if backcheck cushioning is required to begin at a greater degree of door opening than the approximately 75° it is set for.

ELECTRICAL:

Turn power input to unit on.

Selector Mode Switch – Set to the “ON” Position for normal use.

- Adjust "CL/AS DLY" Rotary Switch/Timer Pot on the printed circuit board as necessary using a standard screwdriver with a 1/8" wide blade. Adjustable for 0 to 30 seconds (see chart below).
- Power Assist Function Only: Adjusts the length of time the motor will assist with opening from the time the motor is activated.
- Power Operator Function Only: Adjusts the length of time the door remains at the fully open position after the operator function shuts off.

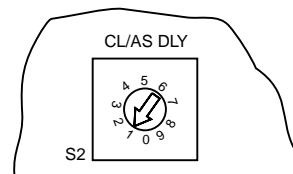

Illustration for CL/AS DLY Rotary Switch/Timer Pot From Printed Circuit Board

Length of Time (Seconds)	Setting
0	0
2	1
5	2
10	3
15	4
20	5
25	6
30	7

- If desired, install No. 668 Security Plate over notch in cover to conceal the Selector Mode Switch when cover is installed.
- Install cover with mounting screws removed at beginning of installation.

General Product Information (See illustrations on page 2 for location of switch and valves.)

- **Selector Mode Switch** – This is a three (3) position switch that has positions marked "OFF" "ON" "H/O".
 - "ON" position – Unit is in standby, capable of function activation either by a remote switch or scanner; or by the unit's integral switch depending upon the Activation Mode.
 - "H/O" position – Indefinite hold open. Door will hold open until power is interrupted.
Power Assist Function Only (PAS).
These units must be manually pushed to the full open position for this indefinite Hold Open function to operate.
 - "OFF" position – All signal inputs are disabled, rendering all power functions inoperative. The unit functions as a standard hydraulic door closer.
- **"SC" Speed Control Valve**
 - Power Assist Function Only.
Adjusts the force required to open the door.

- Power Operator Function Only (POR).
Adjusts the opening speed of the door.

Important: From closed position to 80 degrees must be 3 seconds or longer and 4 seconds or longer to the fully open position.

- **"PA" pressure Adjustment Valve**

Factory set adjustment for opening force. Will not generally require adjustment:

Important: Power Operator Function Only (POR): The force required to prevent a door from opening or closing must not exceed a 15 lbf. (67N) applied 1" (25mm) from the latch edge of the door at any point in the opening or closing cycle.

Function and Operation Sequence

VESTIBULE OPERATION

In either Power Operator or Power Assist Function, initiation of a power cycle may be performed on a delayed basis. This feature, referred to as Vestibule Operation, allows placement of the initiating switch at a remote location from the Door Operator. The adjustable VEST DLY rotary switch/timer pot is provided for selection a length of delay, appropriate for the particular installation. The basic sequence is shown below:

- Initiate vestibule delay cycle JP1-INV from JP1-OUTV of another unit or from a switch.
- Set VEST DLY rotary switch/timer pot to delay initiation of pump motor.
- Upon initiation of pump motor, Power Operator or Power Assist Function will start.

POWER OPERATOR FUNCTION – "POR"

In the power operator function, initiation of the unit causes the operator to fully open the door under its own power, sustain the opened position for a set duration, and then release and close.

The basic sequence is:

1. Initiate power cycle through any of the following JP1 terminal functions: AUX1, AUX2, RFT, JP1-INV, the L1 limit switch input, the H/O of slide switch or the JP1-O/O terminal.

2. If JP1-INV is the power cycle initiating signal, read the VEST DLY rotary switch/timer pot to determine how long to wait before the power cycle starts.
3. Read the EXSOL DLY rotary switch/timer pot to determine how long solenoid should be energized or de-energized, depending upon function required.
4. Read the SW1-2 (A/D) dip switch to determine how long solenoid should be energized.
5. Read the M DLY rotary switch/timer pot to determine how long before the pump motor and solenoid valve turn on.
6. When ELS board reaches upper taught limit, door is fully open.
7. Pump motor turns off.
8. Read the CL/AS DLY rotary switch/timer pot to determine the length of temporary hold open.
9. Solenoid valve turns off, releasing door from temporary hold open.
10. Door closes and operator waits for next power cycle initiation.

Additional door open signals received during Step 8 of the Power Operator function will cause the closing delay timer to be reset to the beginning.

Exceptions to the Power Operator Function

Following is an explanation of the inputs that can modify the basic flow of the Power Operator function described above.

1. If terminal JP1-PDET is signaled the door will not open if it is closed or the door will not close if it is open. This signal is normally used to connect to a presence detector which will prevent the door from opening or closing when someone is in the area of detection. Note that JP1-0/0 will override the PDET signal.
2. If JP1-0/0 is signaled the door will open independently of the state of JP1-PDET or JP2-E signals.
3. If the H/O slide switch is set, the door will open and remain open. JP1-PDET, JP1-0/0 or JP2-E will override the H/O signal.
4. If JP2-E is signaled, the power cycle will terminate and the door will close. JP1-0/0 will override the JP2-E signal.
5. The door must reach its fully open position within 7 seconds after it has started opening or the pump motor and solenoid valve will be turned off allowing the door to close.

6. If the door is in the closed position, and not in the Manual or Emergency mode, signaling RFT will initiate a door power cycle. The door will remain open until PH1-RFT is again signaled or until JP2-E is signaled. If the door is in the open position, the RFT signal will close the door, therefore, the door can be "toggled" between an open and closed position.

POWER ASSIST FUNCTION – "PAS"

In the Power Assist function, initiation of a power cycle causes the pump motor and solenoid valve to engage, requiring minimal force to open or close the door. The ease of operation is sustained for an adjustable duration, after which the motor and solenoid are turned off, causing the door to close. If the door is fully opened during the power cycle, the motor will disengage for the remainder of the cycle. The solenoid will remain engaged for the duration of the cycle. The basic flow for the Power Assist mode is the same as the Power Operator mode except that the 7 second time-out function is not in effect.

ELS Board Calibration



WARNING: Make sure dip switch #3 on ELS board is in the “A” position when performing ELS Board Calibration.
(See Page 2)

The ELS board is calibrated (Timed) to appropriate starting zone at the factory. If for any reason the ELS Board was removed or the ELS Board Pulley was turned without the pinion turning, it is likely the ELS board will need to be re-calibrated (timed).

During a normal installation, this procedure is not required.

The ELS board may be timed while unit is mounted to the door frame. The unit may also be timed off the frame and door with the pinion in the “at rest” position.

- Turn Power to Unit “OFF”.
- Determine Hand of Door to determine which procedure to follow below.
- Remove forearm screws from the arm adjusting rod and disassemble the adjusting rod and arm snubber shoe assembly from the main arm assembly.
- Remove main arm from unit. Snubber shoe assembly can remain on door.
- Loosen two set screws that secure Pinion Timing Pulley to Pinion. (May use main arm to rotate pinion to reveal set screws that may be under the timing belt). Maintain tension on timing belt. Belt should be tensioned such that 1/6” to 1/8” belt deflection is possible. The Pinion Timing Pulley should now be able to freely rotate independent of the pinion.

RH-PUSH UNITS:

- The ELS board will be on the bottom of the unit. (See Front Page).
- While looking up at the ELS board, rotate ELS Board Pulley Clockwise until hard stop is reached.
- Depress and hold Black Button on the ELS Board. While depressing button, turn power input to unit “ON” and continue depressing button until the ELS Board LED flashes three (3) times. The installer then has three (3) seconds to release the button after the LED flashes.
- Slowly rotate the ELS Board Pulley Counter-Clockwise (away from hard stop less than 1/8th turn) until the LED on the ELS board lights.
Note: Pinion pulley should be rotating with the potentiometer pulley during this step. The Pinion should not rotate during this step.
- Using a 5/64” hex wrench, tighten the first setscrew on the pinion pulley, rotate the pinion 90° to reveal the second pulley setscrew and tighten that setscrew as well.**
- The ELS board is now calibrated for a :RH-PUSH Unit.

LH-PUSH UNITS:

- The ELS board will be on the top of the unit. (See Front Page).
- While looking down at the ELS board, rotate ELS Board Pulley Clockwise until hard stop is reached.
- Depress and hold Black Button on the ELS Board. While depressing button, turn power input to unit “ON” and continue depressing button until the ELS Board LED flashes three (3) times. The installer then has three (3) seconds to release the button after the LED flashes.
- Slowly rotate the ELS Board Pulley Counter-Clockwise (away from hard stop less than 1/8th turn) until the LED on the ELS board lights.
Note: Pinion pulley should be rotating with the potentiometer pulley during this step. The Pinion should not rotate during this step.
- Using a 5/64” hex wrench, tighten the first setscrew on the pinion pulley, rotate the pinion 90° to reveal the second pulley setscrew and tighten that setscrew as well.**
- The ELS board is now calibrated for a LH-PUSH Unit.

- Re-assemble and pre-load arm per instructions on page 4.
- Re-teach Closed and Open Positions. See page 5.
- Place the 3 position Selector Mode Switch in the “ON” position for normal operation.

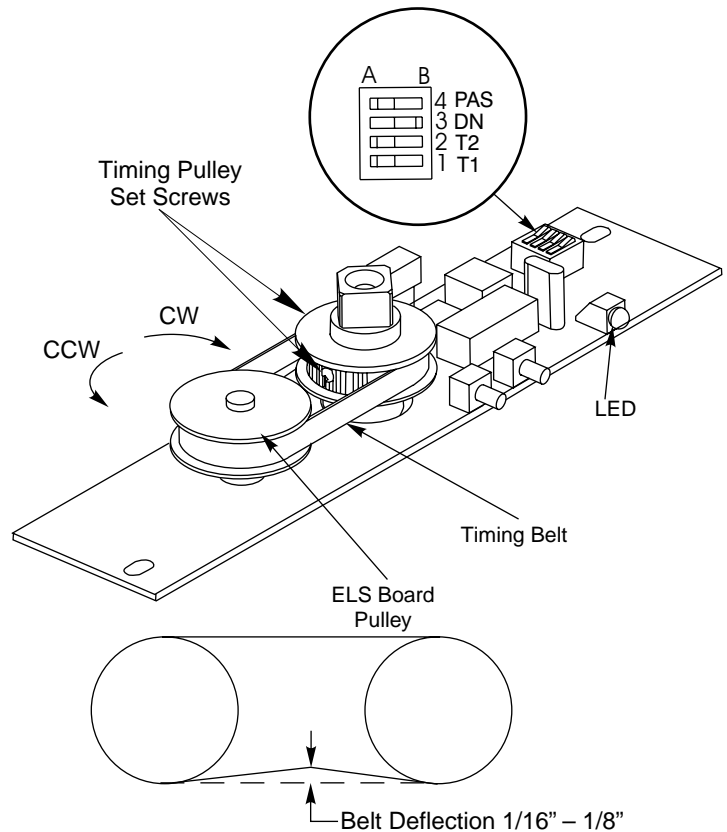

****NOTE:** If LED should turn off during this procedure without any significant movement of ELS Board Pulley, this is not a problem. The timing zone range is large enough to allow for slight movement of this pulley during tightening of set screws.

Note: The ELS board is factory-calibrated without any pre-load on the pinion. When the unit is properly installed, and there is pre-load on the pinion, the light on the ELS board will not be lit. This is not a problem. The light is simply intended to set the potentiometer in the appropriate “zone”.

*** ELS Reset Instructions:**
READ INSTRUCTIONS COMPLETELY BEFORE PROCEEDING

Disconnecting Power to Unit

If power input does not have an interrupt switch near by, power may be terminated at unit by unseating Fuse F2.

- Choose a flat blade screw driver that will fit snugly into slot on fuse holder
- Carefully push on Fuse Holder cap while turning Counter-Clockwise 1/4 turn to unseat fuse holder cap. Gently pull cap out slightly and note if LED on Main Board is Lit. If there is no

Reset ELS Board

- Depress and hold the **Black Button** on the ELS Board. While depressing button, turn power input to unit ON **. The LED on the ELS Board will begin flashing. When the LED flashes three(3) times, the installer has three (3) seconds to release the button.

Reconnect Power to Unit

- To reseal fuse, Carefully push fuse holder cap into holder and turn Clockwise 1/4 turn.

Return to "Teaching Closed and Open Door Positions on Page 5.

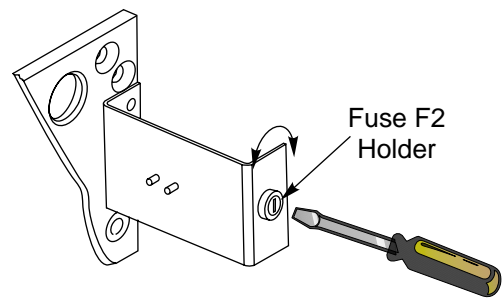

****NOTE:**

When performing this step of the ELS Reset Instructions, you may push on Fuse Holder Cap with screw driver to temporarily engage power so that attention can be directed at the ELS LED. Once the LED has flashed 3 times and the BLACK button released, then the installer may properly reseal the fuse.

Troubleshooting

Because of the sophisticated nature of the PowerMatic product, there are a number of steps during the installation procedure that if overlooked or misapplied, can create incorrect functioning or a complete failure of operation.

- Door Closing Force is Insufficient
 - Increase spring power with Power Adjustment Nut.
 - Check Sweep Speed and Latch Speed regulation valves.
- Door Opening Force is Too Strong
 - Adjust "PA" valve – turn counter clockwise.
- Door Opens Too Fast – Power Operator Function Units Only
 - Adjust "SC" valve – turn counter clockwise.
- Door Does Not Open Far Enough – Power Operator Function Units Only
 - Re-teach door Closed and Open position on the ELS board. (See Page 4)
 - Adjust "PA" valve – turn clockwise.
 - Check "B" backcheck valve – turn counter clockwise.
 - Check template position of unit on the frame and the door.
- PowerMatic Motor shuts off and door closes before reaching full open position.
 - a. This could be caused by the unit sensing an obstruction on Opening.
 1. Verify door can be mechanically opened; check for frame interference.
 2. Check Backcheck setting on closer body. If Backcheck is too strong, unit may be seeing this as an obstruction.
 3. Check "SC" (Speed Control) Valve setting. Door may be opening too slowly. Turn "SC" valve clockwise to increase speed.
 4. There may be wind or some other positive pressure present. Adjust Obstruction Sensitivity to a longer time setting. See page 7.
- PowerMatic Motor turns on and re-activates door before it reaches jamb or closed position.
 - a. This could be caused by the unit sensing an obstruction on Closing.
 1. Check for frame interference.
 2. Verify the transition from sweep speed to latch speed is smooth. If there is an abrupt change in speed or if door stops as it transitions from sweep to latch, the unit will see this as an obstruction.
 4. There may be a wind or some other positive pressure present. Adjust Obstruction Sensitivity to a longer time setting. See page 7.
- Door Does Not Appear to be Receiving Power
 - Selector Mode Switch is in "OFF" position.
 - Check to see if red LED is illuminated on printed circuit board.
 - If yes:
 - Check solenoid and motor connectors and connections, that they are secure.
 - If no:
 - Check incoming power at the input power terminal strip (terminals HOT and COM) to insure that power leads are oriented correctly and are fastened securely.
 - Check fuse "F2".
 - If blown, unplug solenoid and motor lead connectors. Replace fuse and check LED.
 - If illuminated, either the solenoid coil or the motor connections, wire or motor windings are defective.