

320M Series MiniLine™ Electromagnetic Locks Special Application Solution

MagForce™
LIFETIME WARRANTY

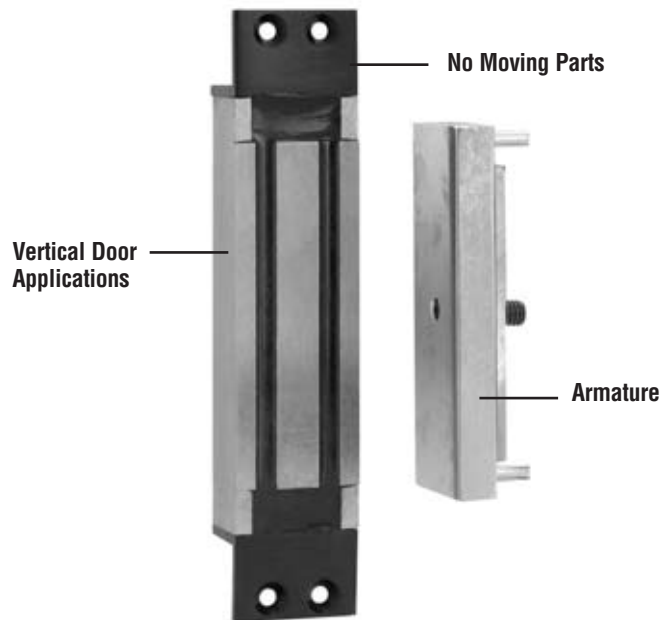

NOTE: Due to the higher ambient operating temperature of mortise wood framed application, it is **REQUIRED** that the 12V/0.225 AMP configuration be used.

Locknetics provides the industry's most complete selection of electromagnetic locks. The 320M Series MiniLine of speciality electromagnetic locks include the 320M mortise mounted system. The 320M Series is designed to interface with electronic access control systems, automatic door operators, and fire or hazard sensing systems, to provide egress upon detectable emergency. With no moving parts and a fail safe design, it offers an excellent solution for both security and life safety requirements when connected to the fire alarm circuit.

The 320M Series has been installed on thousands of worldwide installations including airports, hospitals, nursing homes, schools, universities, libraries, museums, retail and office buildings, laboratories, and government installations.

The 320M Series MiniLine is UL listed and engineered to meet the ANSI/BHMA standard for electromagnetic locks.

Benefits of Using 320 M Series

- Mortise mount for sliding doors
- Includes mounting tabs and armature mounting block
- Low maintenance - No moving parts
- Meets Security and Life Safety requirements
- Fields Selectable 12 or 24 VDC operation

500 to 650 lbs.
Holding Force



CSFM
MEA 14-95-6

320M Series MiniLine Electromagnetic Locks Special Application Solution

How To Order 320 M Series

320M – DSM/MBS

Select Model
Select Options

1. Select Model

320M Mortise Mount - Sliding Doors
Includes lock mounting tabs.
12/24 VDC Single

2. Select Options

ATD Adjustable Time Delay
DSM Door Status Monitor
MBS Magnetic Bond Sensor
DSM/MBS Door Status Monitor/Magnetic Bond Sensor
RCP Rectifier (for use with AC)

Specifications:

Holding Force: 500 LBS @ 12VDC
650 LBS @ 24 VDC

Input Voltage: 12/24 VDC

Current Draw: .23A @ 24VDC
.45A @ 12VDC

Wiring: Wire leads 12" long
MTG Type: Concealed

Lock Body

Length: 7"

Height: 1³/₈"

Depth: 1⁷/₈"

Armature

Length: 4¹/₄"

Height: 1¹/₂"

Depth: 5/8"

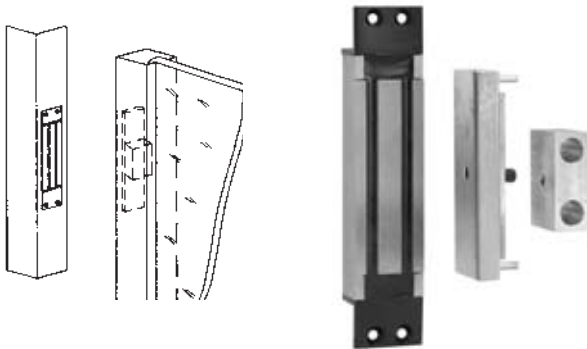

320M Series

For vertical mount in sliding door assemblies