

# PUSH SIDE - HEADER MOUNTING

HOLD OPEN FROM 90° - 180°

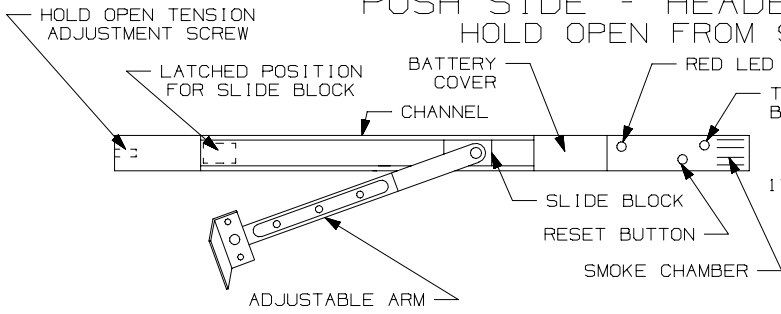

FIGURE 1

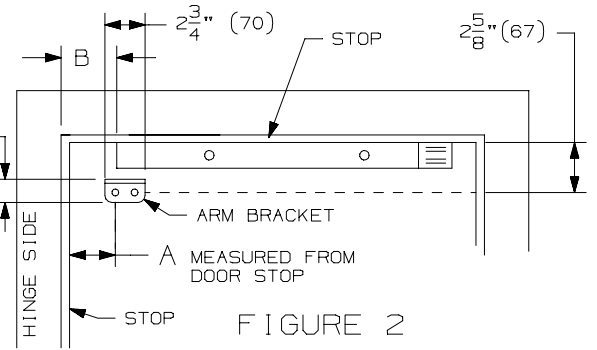

FIGURE 2

**INSTRUCTIONS:**

1. REMOVE BATTERY COMPARTMENT COVER (SEE FIG. 1) AND INSTALL ALKALINE 9-VOLT BATTERY. THE RED LED SHOULD NOW FLASH ONCE EVERY SECOND AND THE MOTOR WILL RUN BRIEFLY.
2. REINSTALL THE BATTERY COVER AND ATTACH WITH BOTH SCREWS. THE RED LED SHOULD STOP FLASHING 3 SECONDS AFTER SECURING 2ND SCREW. THE RED LED WILL NOW BEGIN FLASHING ONCE EVERY 40 SECONDS.
3. WAIT 15 SECONDS.
4. PRESS AND HOLD THE "RESET" BUTTON FOR 2 SECONDS. YOU SHOULD HEAR THE MOTOR RUN BRIEFLY. IF YOU DO NOT HEAR THE MOTOR RUN, WAIT 15 SECONDS AND TRY AGAIN.
5. SELECT PROPER "B" DIMENSION FROM TABLE 1.
6. CLOSE THE DOOR AND PLACE UNIT AGAINST BOTTOM OF STOP (SEE FIG. 2)
7. LEAVE A 1/8" GAP BETWEEN THE DOOR AND THE UNIT (SEE FIG.3)
8. USING THE UNIT AS A TEMPLATE, MARK THE LOCATION OF THE 3 MOUNTING HOLES IN THE STOP.
9. DRILL THE 3 MOUNTING HOLES WITH A 13/64" BIT AND TAP 1/4-20.
10. INSTALL THE UNIT ONTO THE STOP WITH THE 3 MACHINE SCREWS AND LOCK WASHERS.
11. SELECT PROPER "A" DIMENSION FROM TABLE 1.
12. MARK THE BRACKET HOLE LOCATIONS ON THE DOOR (SEE FIG.2)
13. LOOSEN ARM SET SCREWS (SEE FIG. 4)
14. FOR 180° HOLD OPEN, MOVE THE ARM TO THE BRACKET HOLE CLOSEST TO THE HINGE. OTHERWISE, LEAVE ARM IN CENTER BRACKET HOLE. INSTALL ARM BRACKET USING SEX BOLTS, LOCK WASHERS, AND SEX NUTS (SEE FIG 4)
15. MOVE THE SLIDE BLOCK TO THE LATCHED POSITION (SEE FIG 1)
16. OPEN THE DOOR TO THE DESIRED HOLD OPEN ANGLE.
17. TIGHTEN ARM SET SCREWS (SEE FIG 4) THE DOOR SHOULD NOW BE HELD OPEN.
18. MANUALLY OPEN AND CLOSE THE DOOR SEVERAL TIMES TO CHECK THE HOLD OPEN POSITION.
19. MANUALLY MOVE THE DOOR INTO HOLD OPEN POSITION.
20. PRESS THE "TEST" BUTTON TO SIMULATE A FIRE CONDITION. DOOR SHOULD RELEASE FROM HOLD OPEN.
21. WAIT 15 SECONDS.
22. PRESS THE "RESET" BUTTON TO RESET THE UNIT.
23. MANUALLY MOVE THE DOOR INTO HOLD OPEN POSITION. DOOR SHOULD NOW BE HELD OPEN.
24. IF DESIRED, ADJUST HOLD OPEN TENSION BY TURNING ADJUSTMENT SCREW CLOCKWISE TO INCREASE OR COUNTERCLOCKWISE TO DECREASE (SEE FIG 1)

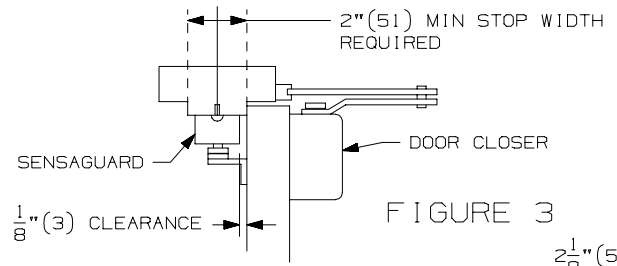

FIGURE 3

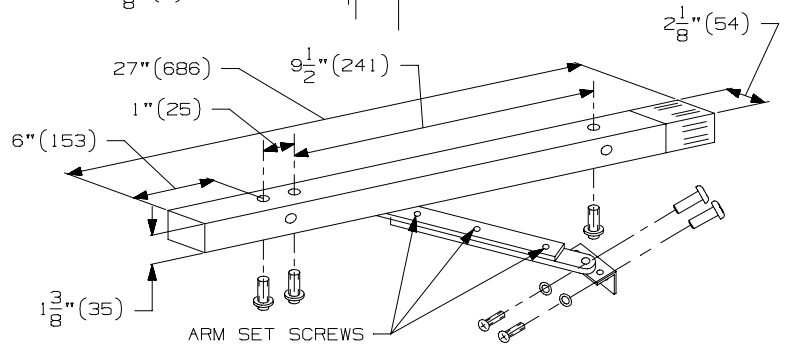

FIGURE 4

TABLE 1

DEGREES HOLD OPEN	90° - 130°	130° - 180°
A	4 1/2" (114)	1/2" (13)
B	5" (127)	3" (76)

SCREW DETAILS		
	QTY	DESCRIPTION
PUSH SIDE CHANNEL	3	1/4-20 x 1/2" PHMS
	3	1/4" SPLIT LOCK WASHER
PULL SIDE CHANNEL	2	1/4-20 x 1/2" SHCS
ARM BRACKET*	2	1/4-20 x 3/4" TRUSS PHMS
	2	1/4-20 SEX BOLTS
	2	1/4" SPLIT LOCK WASHER
CHANNEL HOLE PLUGS	4	PAINTED PLASTIC HOLE PLUGS

\*THE SCREW COMES INSTALLED IN SEX BOLT

SENSAGUARD™ 280  
INSTALLATION TEMPLATE



NOTE: DIMENSIONS IN ( ) ARE MILLIMETERS.

TEMPLATE NUMBER: INST. 280\_OSHT 1      DATE: 03-04-02

# PULL SIDE - FACE MOUNTING

HOLD OPEN FROM 90° - 130°

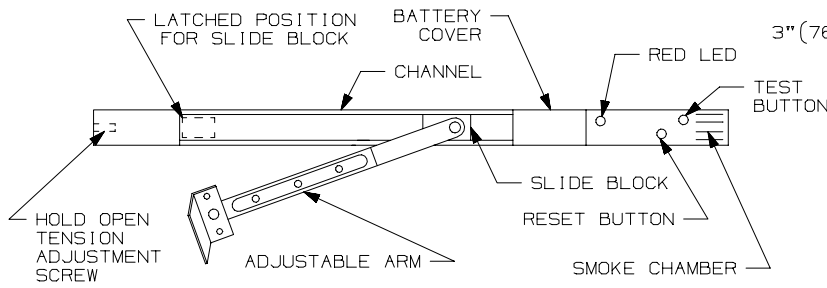

FIGURE 1

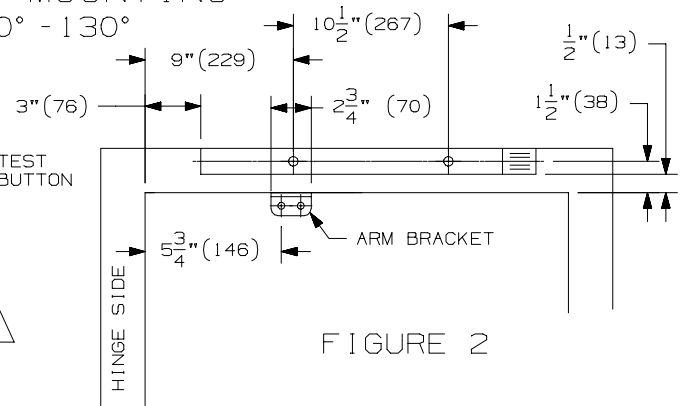

FIGURE 2

## INSTRUCTIONS:

1. REMOVE BATTERY COMPARTMENT COVER (SEE FIG. 1) AND INSTALL ALKALINE 9-VOLT BATTERY. THE RED LED SHOULD NOW FLASH ONCE EVERY SECOND AND THE MOTOR WILL RUN BRIEFLY.
2. REINSTALL THE BATTERY COVER AND ATTACH WITH BOTH SCREWS. THE RED LED SHOULD STOP FLASHING 3 SECONDS AFTER SECURING 2ND SCREW. THE RED LED WILL NOW BEGIN FLASHING ONCE EVERY 40 SECONDS.
3. WAIT 15 SECONDS.
4. PRESS AND HOLD THE "RESET" BUTTON FOR 2 SECONDS. YOU SHOULD HEAR THE MOTOR RUN BRIEFLY. IF YOU DO NOT HEAR THE MOTOR RUN, WAIT 15 SECONDS AND TRY AGAIN.
5. PLACE UNIT AGAINST FRAME. (SEE FIG. 2 & 3)
6. USING THE UNIT AS A TEMPLATE, MARK THE LOCATION OF THE 2 CHANNEL MOUNTING HOLES.
7. DRILL THE 2 MOUNTING HOLES WITH A 13/64" BIT AND TAP 1/4-20.
8. INSTALL THE UNIT ONTO THE FRAME WITH THE 2 SOCKET HEAD CAP SCREWS.
9. MARK THE BRACKET HOLE LOCATIONS ON THE DOOR (SEE FIG.2)
10. LOOSEN ARM SET SCREWS (SEE FIG. 4)
11. INSTALL ARM BRACKET USING SEX BOLTS, LOCK WASHERS, AND SEX NUTS (SEE FIG 4)
12. MOVE THE SLIDE BLOCK TO THE LATCHED POSITION (SEE FIG 1)
13. OPEN THE DOOR TO THE DESIRED HOLD OPEN ANGLE.
14. TIGHTEN ARM SET SCREWS (SEE FIG 4) THE DOOR SHOULD NOW BE HELD OPEN.
15. MANUALLY OPEN AND CLOSE THE DOOR SEVERAL TIMES TO CHECK THE HOLD OPEN POSITION.
16. MANUALLY MOVE THE DOOR INTO HOLD OPEN POSITION.
17. PRESS THE "TEST" BUTTON TO SIMULATE A FIRE CONDITION. DOOR SHOULD RELEASE FROM HOLD OPEN.
18. WAIT 15 SECONDS.
19. PRESS THE "RESET" BUTTON TO RESET THE UNIT.
20. MANUALLY MOVE THE DOOR INTO HOLD OPEN POSITION. DOOR SHOULD NOW BE HELD OPEN.
21. IF DESIRED, ADJUST HOLD OPEN TENSION BY TURNING ADJUSTMENT SCREW CLOCKWISE TO INCREASE OR COUNTERCLOCKWISE TO DECREASE (SEE FIG 1)

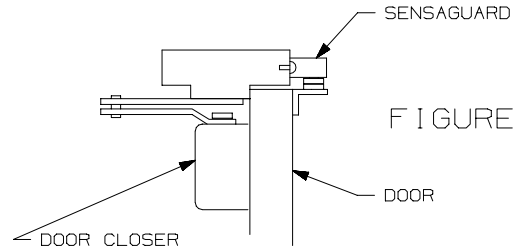

FIGURE 3

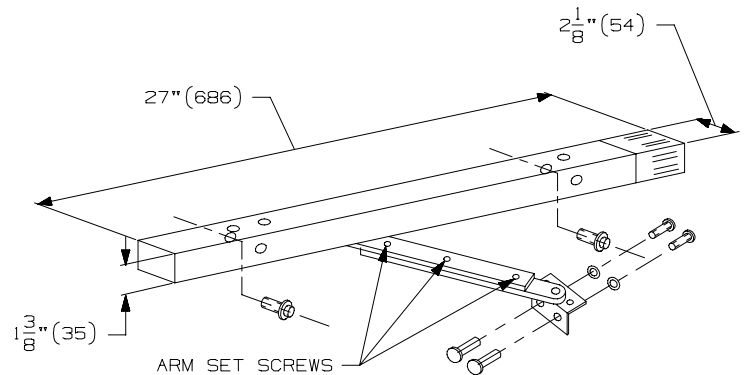

FIGURE 4

SCREW DETAILS		
	QTY	DESCRIPTION
PUSH SIDE CHANNEL	3	1/4-20 x 1/2" PHMS
	3	1/4" SPLIT LOCK WASHER
PULL SIDE CHANNEL	2	1/4-20 x 1/2" SHCS
ARM BRACKET*	2	1/4-20 x 3/4" TRUSS PHMS
	2	1/4-20 SEX BOLTS
	2	1/4" SPLIT LOCK WASHER
CHANNEL HOLE PLUGS	4	PAINTED PLASTIC HOLE PLUGS
*THE SCREW COMES INSTALLED IN SEX BOLT		

SENSAGUARD™ 280  
INSTALLATION TEMPLATE

**IR** GLYNN-JOHNSON

NOTE: DIMENSIONS IN ( ) ARE MILLIMETERS.

TEMPLATE NUMBER: INST. 280\_OSHT2 DATE: 03-06-02

PROBLEM	COMMENTS
DOOR WILL NOT HOLD OPEN	<ol style="list-style-type: none"> <li>1. CHECK IF 9-VOLT ALKALINE BATTERY IS INSTALLED AND BATTERY COVER IS ATTACHED WITH BOTH SCREWS.</li> <li>2. DOES RED LED FLASH WHEN "TEST" BUTTON IS PUSHED AND HELD? IF YES, CONTINUE, IF NO, CALL GJ TECHNICAL SUPPORT AT (888)371-7331.</li> <li>3. WAIT 15 SECONDS.</li> <li>4. PUSH AND HOLD "RESET" BUTTON FOR 2 SECONDS.</li> <li>5. MOVE DOOR TO DESIRED HOLD OPEN ANGLE AND SEE IF HOLD OPEN MECHANISM CATCHES. IF NO, CONTINUE.</li> <li>6. DOES SLIDE BLOCK INSIDE CHANNEL TRAVEL COMPLETELY TO THE END OF TRACK WHEN THE DOOR IS FULLY OPEN? IF NOT, ADJUST (SHORTEN) THE ARM LENGTH. NOTE: THE SLIDE BLOCK MUST TRAVEL TO THE END OF THE CHANNEL TO ENGAGE THE LATCH MECHANISM.</li> <li>7. IF UNIT STILL WILL NOT HOLD OPEN, CALL GJ TECHNICAL SUPPORT AT (888)371-7331.</li> </ol>
DOOR WILL NOT RELEASE WHEN "TEST" BUTTON IS PUSHED	<ol style="list-style-type: none"> <li>1. WAIT 15 SECONDS.</li> <li>2. PUSH AND HOLD "TEST" BUTTON FOR 2 SECONDS.</li> <li>3. IF UNIT DOES NOT RELEASE, MAKE SURE DOOR IS NOT HUNG UP ON FRAME OR THE FLOOR AND THAT THE CLOSER IS WORKING PROPERLY. IF UNIT STILL DOES NOT RELEASE, CALL GJ TECHNICAL SUPPORT AT (888) 371-7331.</li> </ol>
DOOR IS DIFFICULT TO RELEASE FROM HOLD OPEN MANUALLY	<ol style="list-style-type: none"> <li>1. ADJUST TENSION BY TURNING HOLD OPEN TENSION ADJUSTMENT SCREW.</li> <li>2. CHECK TO SEE IF UNIT IS SECURELY ATTACHED TO THE DOOR AND FRAME. IF THE UNIT ROCKS ON THE FRAME, THE RELEASE MECHANISM MAY BIND UP DURING MANUAL RELEASE.</li> </ol>
DOOR WILL NOT SHUT COMPLETELY	<ol style="list-style-type: none"> <li>1. CHECK IF ADJUSTABLE ARM RUBS OR CONTACTS ANY PART OF THE CHANNEL. IF IT DOES, THE ARM MAY BE ADJUSTED TOO LONG, THE DOOR BRACKET MAY BE MOUNTED TOO HIGH, OR THE CHANNEL IMPROPERLY LOCATED. VERIFY TEMPLATE DIMENSIONS.</li> </ol>
DOOR WILL NOT HOLD OPEN AFTER "SMOKE TEST"	<ol style="list-style-type: none"> <li>1. AS LONG AS SMOKE IS IN THE DETECTION CHAMBER, THE RED LED WILL BE FLASHING. WAIT FOR ALL SMOKE TO DISSIPATE, THEN PRESS "RESET" BUTTON, WAIT 15 SECONDS, AND TRY AGAIN.</li> </ol>

SENSAGUARD™ 280  
INSTALLATION TEMPLATE



NOTE: DIMENSIONS IN ( ) ARE IN MILLIMETERS

TEMPLATE NUMBER: INST.280\_OSHT3

DATE: 03-06-02

# GLYNN-JOHNSON SENSAGUARD™ 280 GENERAL INFORMATION

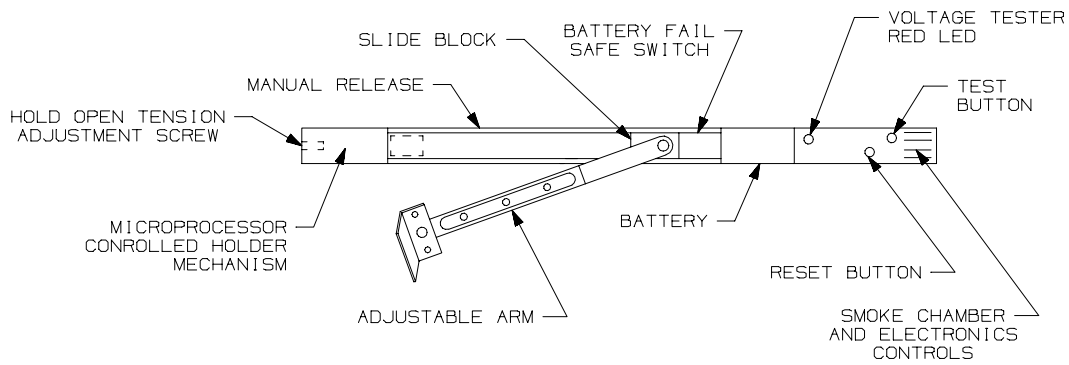

- TEST BUTTON.....PUSH FOR 2 SEC. TO RELEASE DOOR HOLDER
- RESET BUTTON.....PUSH FOR 2 SEC. TO RESET HOLDER.  
(WAIT 15 SEC. BETWEEN TEST AND RESET)
- SMOKE CHAMBER.....IONIZATION CHAMBER DETECTS SMOKE AND  
PARTICLES OF COMBUSTION - SIGNALING A  
HELD OPEN DOOR TO RELEASE
- LED VOLTAGE TESTER..MONITORS THE BATTERY VOLTAGE ONCE EVERY  
40 SEC. A LOW BATTERY CONDITION WILL SIGNAL  
THE HOLDER TO RELEASE, THUS PROVIDING A FAIL  
SAFE CONDITION
- BATTERY HOLDER.....USES STANDARD 9 VOLT EVEREADY ENERGIZER #522  
BATTERY OR DURACELL #MN1604. DO NOT  
SUBSTITUTE OTHER BRANDS
- FAIL SAFE SWITCH....REMOVAL OF BATTERY COVER CAUSES A HELD OPEN  
DOOR TO RELEASE. A GOOD BATTERY MUST BE  
INSTALLED AND THE COVER IN PLACE BEFORE  
HOLDER CAN BE ACTIVATED
- SLIDE BLOCK.....ENGAGES HOLDER MECHANISM TO HOLD DOOR OPEN
- ADJUSTABLE ARM.....CONNECTS DOOR TO SLIDE BLOCK. ADJUSTABLE  
FOR SINGLE POINT HOLD OPEN.  
90° -130° WHEN PULL SIDE MOUNTED  
90° -180° WHEN PUSH SIDE MOUNTED
- MICROPROCESSOR.....MECHANISM "HOLDS" WHEN RESET SWITCH IS PUSHED.
- HOLDER MECHANISM....MECHANISM "RELEASES" WHEN:  
TEST BUTTON IS PUSHED  
SMOKE IS DETEDED  
BATTERY VOLTAGE IS LOW  
BATTERY IMPEDANCE HIGH  
BATTERY COVER REMOVED
- MANUAL RELEASE.....PULLING DOOR TOWARD THE CLOSED POSITION WILL RELEASE  
THE HOLDER MECANISM. PUSHING THE DOOR FULLY OPEN WILL  
RESET THE HOLDER

REPLACE BATTERY YEARLY ON A REGULAR MAINTENANCE SCHEDULE

NOTE: A HELD OPEN DOOR WILL RELEASE AUTOMATICALLY WHEN SMOKE IS DETEDCTED.  
IT IS NECESSARY TO PUSH THE RESET BUTTON AFTER THE SMOKE CLEARS THE  
CHAMBER. THIS WILL REARM THE HOLDER MECHANISM.

SENSAGUARD™ 280  
INSTALLATION TEMPLATE



NOTE: DIMENSIONS IN ( ) ARE MILLIMETERS.

TEMPLATE NUMBER: INST.280\_OSHT4

DATE: 03-06-02